

RT1 Robot Terminal 1



【 User Manual 】

【Version 3.10】

2007. 8. 2.

株式会社ダイナックス

〒183-0055 東京都府中市府中町1-12-7 TEL:042-360-1621

〒558-0041 大阪府大阪市住吉区南住吉1-19-1 TEL:06-6606-4860

DYNAX CORPORATION

1-12-7-1001 FUCHU-CHO, FUCHU-SHI, TOKYO, JAPAN 183-0055 FAX:042-360-1837
1-19-1 MINAMISUMIYOSHI, SUMIYOSHI-KU, OSAKA, JAPAN 558-0041 FAX:06-6606-5160

- Index -

【1: Outline of RT1】	1
【2: Specification of RT1 and OEM support】	1
【2-1: Standard Specification】	1
【2-2: OEM Support】	1
【2-3: Dimensional Outline Drawing】	2
【CF function type】	2
【3: RT1 RS232C Cable Signal】	3
【3-1: Example of Connection Specification】	3
【3-2: Treatment of Emergency Stop Signal of RT1】	4
【3-3: Treatment of Dead-man Key】	4
【3-4: Communication Parameters of RT1】	5
【4: Key, LED Layout and Key Code of RT1】	5
【5: Display of RT1】	6
【Appendix: RT1 LCD Character Code Table】	7
【RT1 Type】	8

【1: Outline of RT1】

RT1 is a compact, lightweight **robot terminal** focused on easy handling. A push-lock emergency stop button and an optional dead-man key are adopted to enhance the safety of robot operation. This feature is optimal for an operation console of automated machinery control. Two standard cable lengths, 2m and 5m, are available. Its compact and easy-to-hold shape which fits nicely in your hand makes **RT1** superior in handling.

RT1, being designed and produced originally, also supports OEM. A customized console can be provided for a low price and the following customizations are possible: changing keyboard sheet, case color, input power voltage, and communication protocol, applying conductive coating, attaching magnetic rubber, etc.

【2: Specification of RT1 and OEM support】

【2-1: Standard Specification】

Key Switch

Mechanical key switches are implemented (5 × 8 + 4 keys)

Light key-touch is realized by micro switch structure

Display

LCD display with 4 lines of 20 characters each

Emergency stop button

Push-lock emergency stop button is implemented

Possibly used as industrial robot terminal

Interface

Communication by RS232C/RS422(optional)

Max 19,200bps

Power and Capacity

DC5V : 220mA max

DC12V (specify at order) : 210mA max

DC24V (optional) : 60mA max

Ambient Temperature for Usage

0 ~ 40

Dimension / Weight

User-friendly, compact and light-weight terminal is realized

Dimension : 200 × 87 × 25.5 (mm)

Weight : 290 (g) (CF-type is 370g.)

Shape

Easy-to-handle shape

Comfortable grip focused on the fit

【2-2: OEM Support】

RT1 can be customized to the user's specification with low cost

- key board sheet
- user exclusive original sticker
- input power voltage
- communication protocol
- case color
- cable specification (cable length, connector, connection form, etc)
- dead-man key
- magnetic rubber
- with noise cut core
- with CF function
- conductive coating
- emergency stop button guard

【2-3: Dimensional Outline Drawing】

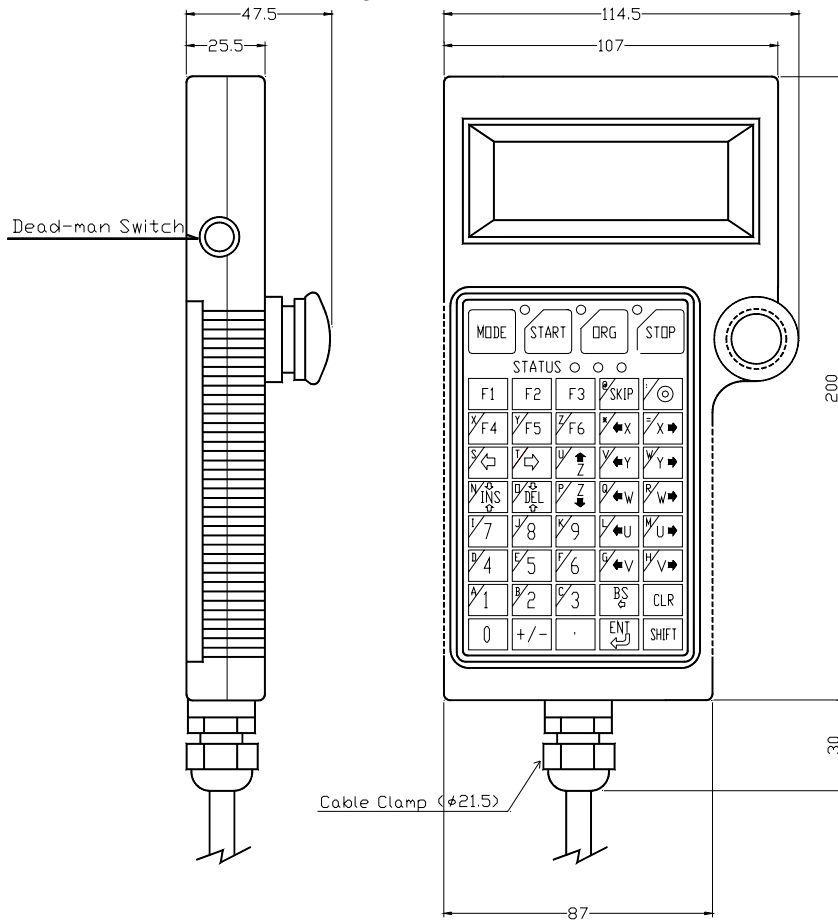

【CF function type】

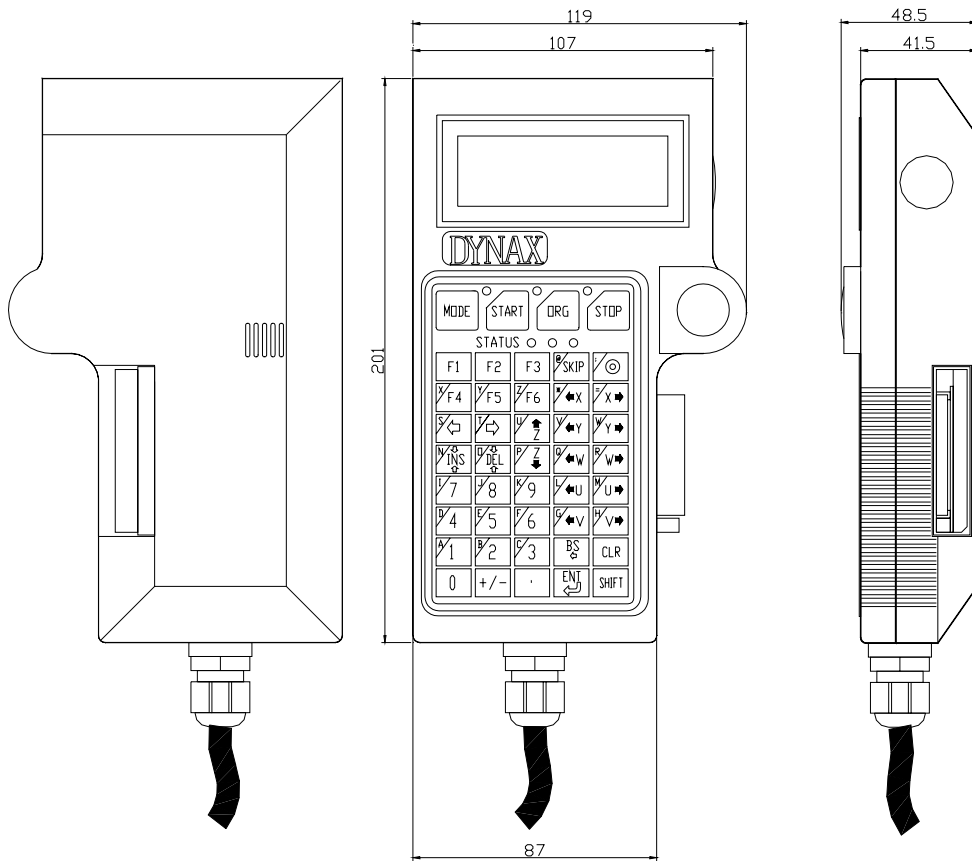

【3: RT1 RS232C Cable Signal】

【3-1: Example of Connection Specification】

There are 3 types of standard connection as follows.

Figure 1 is an example of simple connection with CPU. In this example, the emergency stop signal is output as DTR signal. When cable is disconnected, the emergency stop signal will not be input to CPU. In figure 2, and 3, the emergency stop signal is output as the emergency stop signal.

CPU is a brand name for positioning controller made by DYNAX.

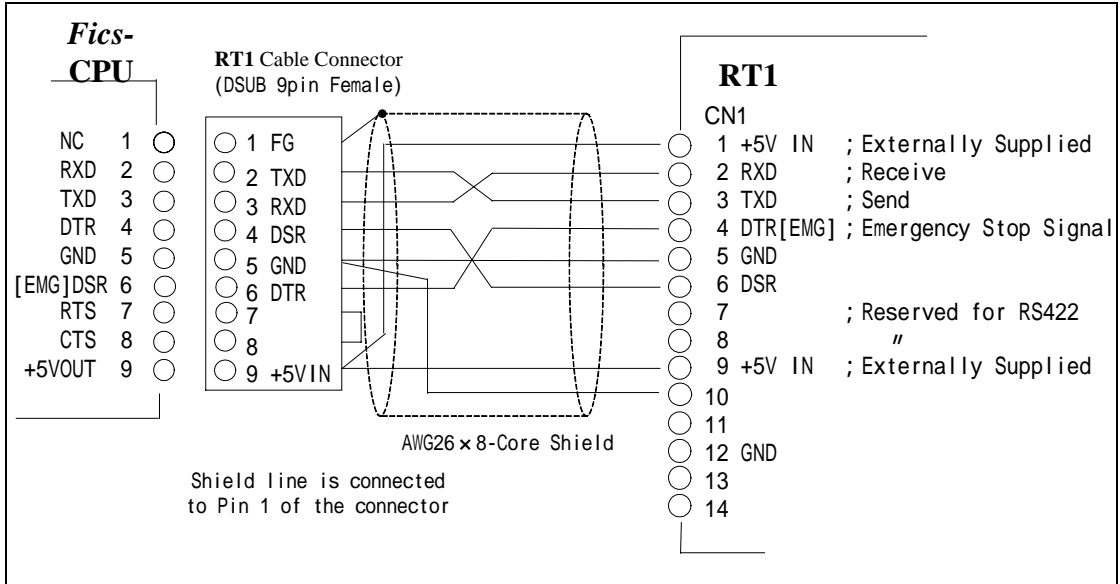

Figure 1: Standard connector, RS232C, emergency stop DTR output type

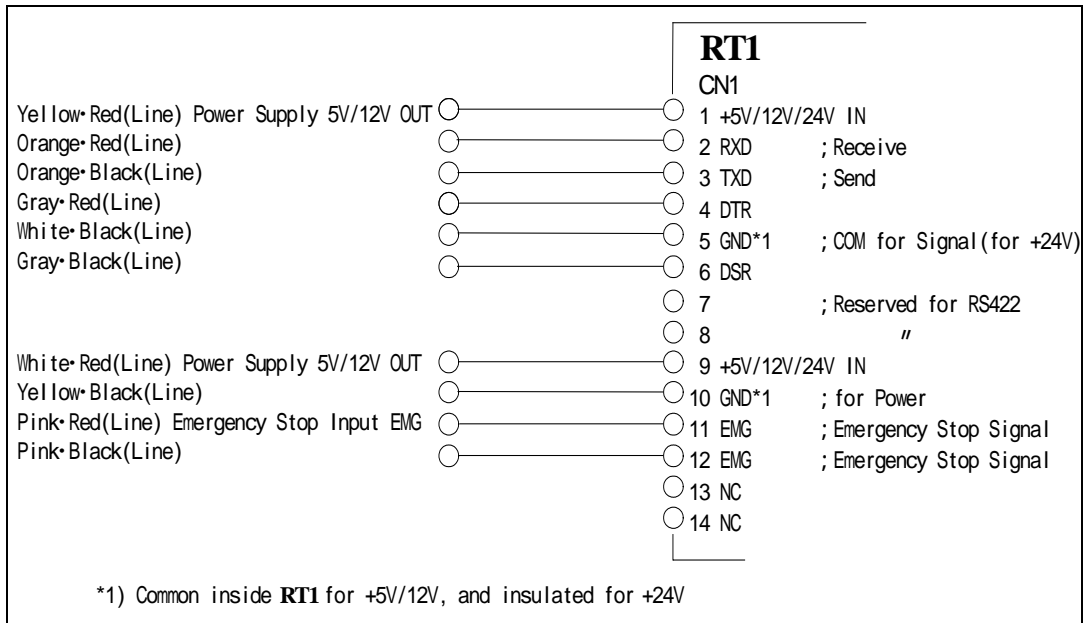

Figure 2: User specified connector, RS232C, emergency stop switch directly connected type

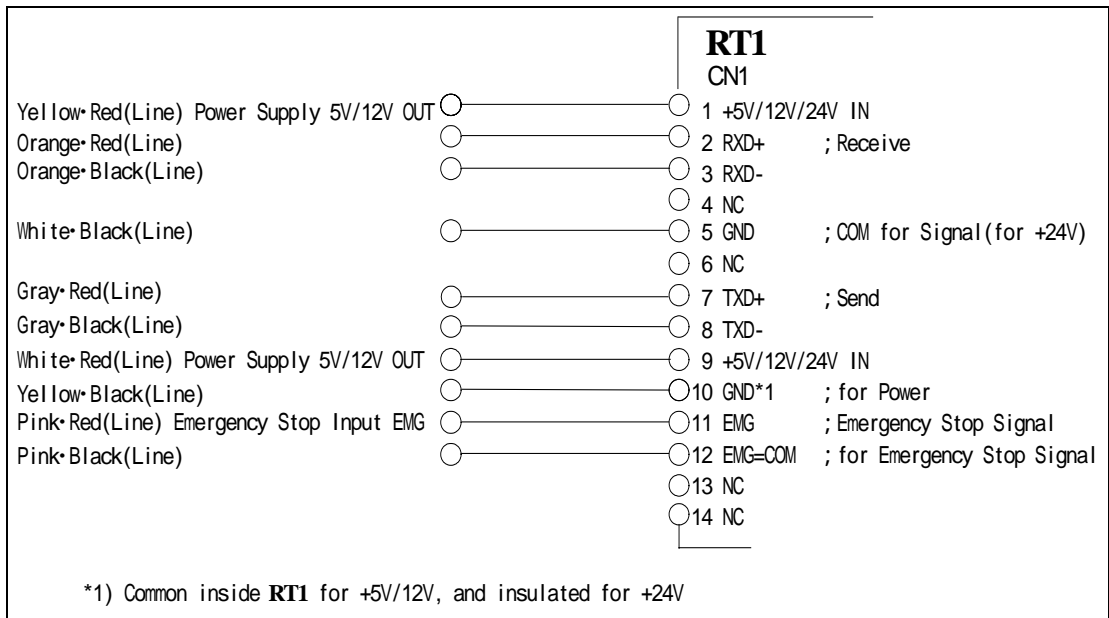
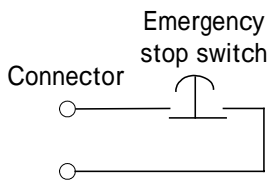

Figure 3: User specified connector, RS422, emergency stop photo-coupler (A-contact point) output type

【3-2: Treatment of Emergency Stop Signal of **RT1**】

If the emergency stop signal of **RT1** is a directly connected type, the contact point (B-contact point) of the emergency stop switch is output directly to the connector. That is, CPU software of **RT1** is not intervened.



【3-3: Treatment of Dead-man Key】

Dead-man key (optional) of **RT1** outputs the contact point (A-contact point) of the dead-man key switch directly to the connector. That is, CPU software of **RT1** is not intervened.

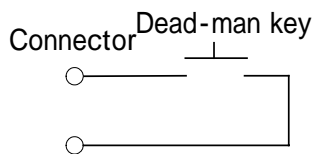

【3-4: Communication Parameters of RT1】

Communication parameters of **RT1** can be set and changed by the following operations.

The following setting screen (1) is displayed by pressing **SHIFT** + **CLR** + **MODE** simultaneously.

```

== RT1 V2.22 ==
<F1> <F2> <F3> <CLR>
NEXT CHNG SAVE QUIT
BAUD RATE = 9600
    
```

* Communication is not established at this time.

Parameters can be changed by manipulating <F1><F2><F3><CLR> keys.

By pressing <F1> key, the screen can be switched to the following setting screens (1) to (5).

- | | | | |
|----------------------|------------------|---|--------------------------------------------|
| (1) BAUD RATE = 9600 | Baud rate | : | 300/600/1200/2400/4800/ 9600 /19200 |
| (2) DATA BITS = 8 | Data length | : | 8 /7 |
| (3) PARITY = NONE | Parity | : | NONE /EVEN/ODD |
| (4) STOP BITS = 1 | Stop bits length | : | 1 /2 |
| (5) KEY BREAK = CODE | Key break | : | NONE /ZERO/ CODE |

Default values are shown in bold characters.

Select each of the parameters by pressing <F2> key.

<F3> key is used to update the setting parameters, and the following screen appears.

Pressing <CLR> key ends the setting screen.

```

<F1> <F2> <F3> <CLR>
YES                               No
ARE YOU SURE ?
    
```

Update parameters

{ YES ; Update
No ; Do not update

【4: Key, LED Layout and Key Code of RT1】

There are two types of key & LED layouts for RT1: (1) 1-Axis Type and (2) Multi-Axis Type.

The 《key code》 of **RT1** is shown in the lower right of each key.

LCD display consists of 20 characters x 4 rows.

(1) 1-Axis Type

(2) Multi-Axis Type

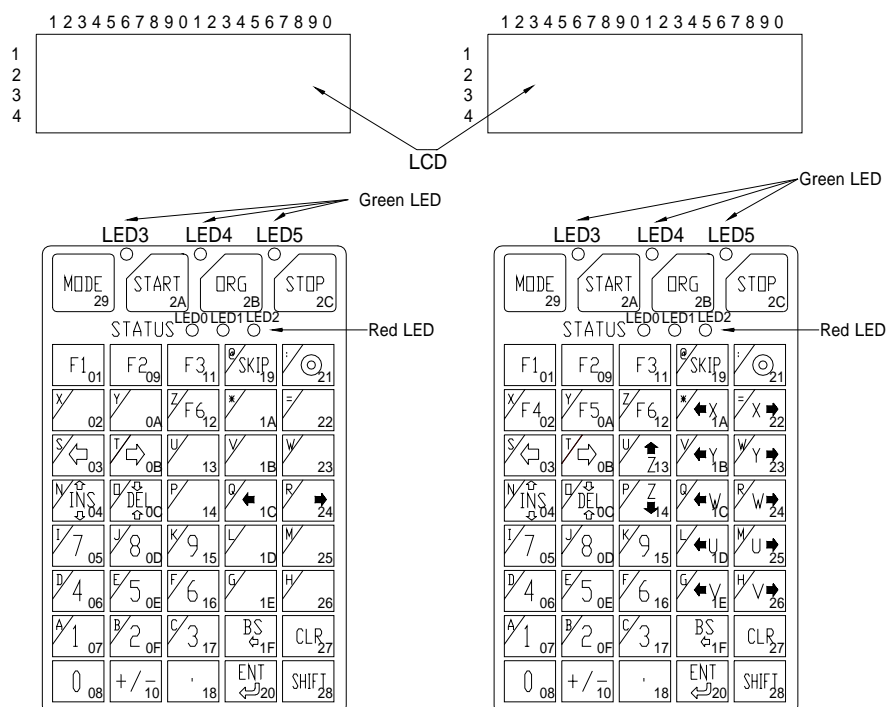

【5: Display of RT1】

In the LCD screen of **RT1**, the ASCII character received by RS232C appears on the cursor. The cursor moves from left to right as the character is received and displayed. When the cursor is at the end of line (the right edge of the screen), it moves to the beginning of the next line. When the cursor is at the end of the last line, it moves to the beginning of the first line.

* Refer to 【Appendix】 for the characters displayed by ASCII code.

The characters between 00h ~ 1Fh and 80h ~ 9Fh are considered to be the error codes except for the following codes. If an error code XX is input, the error display '≡ XX ≡' appears on the LCD screen.

- 00h(RT1) : Inquiry code for connection (**RT1** sends 00h in response)
- 08h(BS) : Backspace code (A cursor and a character string from the cursor position to the end of the line move one digit to the left. The cursor does not move if it is at the left edge of the line.)
- 0Ah(LF) : Line feed code (A cursor moves to the same digit position on the next line. The cursor does not move if it is on the last line.)
- 0Dh(CR) : Carriage return code (A cursor moves to the beginning of the same line.)
- 1Bh(ESC) : Escape code

The escape sequence represented by the escape code (1Bh) + 1 character has a special meaning as follows. Be cautious that the improper format of the LED ON/OFF instruction which begins with ESC[does not guarantee proper operation.

ESC A	Cursor UP	Move cursor 1 line up
ESC B	Cursor Down	Move cursor 1 line down
ESC C	Cursor Right	Move cursor 1 digit to the right
ESC D	Cursor Left	Move cursor 1 digit to the left
ESC E	Clear Display & Home Cursor	Clear display, and move cursor to upper left
ESC F	Cursor On	Display cursor
ESC G	Cursor Off	Erase cursor
ESC H	Cursor Home	Move cursor to upper left
ESC J	Erase To End Of Screen	Erase from cursor to end of screen
ESC K	Erase To End Of Line	Erase from cursor to end of line
ESC L	Long Bell	Ring a long buzzer
ESC M	Erase Line	Erase cursor line
ESC N	Key Brake Code	Generate 《key code》 when key is pressed, generate 《key code + 80h》 when key is released
ESC O	Key Brake None	Generate 《key code》 when key is pressed, do nothing when key is released
ESC P	Key Brake Zero	Generate 《key code》 when key is pressed, generate 《00h》 when key is released
ESC R	Enable Cursor Blink	Blink cursor
ESC S	Disable Cursor Blink	Disable cursor blink
ESC T	Short Tone	Ring a short buzzer
ESC U	Enable Key Click	Enable clicking sound when key is pressed
ESC V	Disable Key Click	Disable clicking sound when key is pressed
ESC Y Pr Pc	Position Cursor At Pr,Pc	Move cursor to line Pr and digit Pc Row1, Col1=(20h+row position)、(20h+column position)
ESC Z	Report Device ID	Send RT1 identification code (' RT1 V2.30 ')
ESC[0a	LED0 ON	Turn LED0 On
ESC[1a	LED1 ON	Turn LED1 On
ESC[2a	LED2 ON	Turn LED2 On
ESC[3a	LED3 ON	Turn LED3 On
ESC[4a	LED4 ON	Turn LED4 On
ESC[5a	LED5 ON	Turn LED5 On
ESC[0b	LED0 OFF	Turn LED0 Off
ESC[1b	LED1 OFF	Turn LED1 Off
ESC[2b	LED2 OFF	Turn LED2 Off
ESC[3b	LED3 OFF	Turn LED3 Off
ESC[4b	LED4 OFF	Turn LED4 Off
ESC[5b	LED5 OFF	Turn LED5 Off

Connection Test: **RT1** connection can be verified by sending 00h to **RT1** and receiving 00h. Be cautious that sending 00h during ESC sequence does not guarantee proper operation.

【Appendix: RT1 LCD Character Code Table】

The mapping table of fonts and character codes of **RT1** is shown below.

High 4 bits Low 4 bits	0000	0001	0010	0011	0100	0101	0110	0111	1000	1001	1010	1011	1100	1101	1110	1111
xxxx0000	RT1			0	@	P	`	p				-	タ	ミ		P
xxxx0001			!	1	A	Q	a	q			。	ア	チ	ム	a	Q
xxxx0010			"	2	B	R	b	r			「	イ	ツ	メ		
xxxx0011			#	3	C	S	c	s			」	ウ	テ	モ		
xxxx0100			\$	4	D	T	d	t			、	エ	ト	ヤ	μ	
xxxx0101			%	5	E	U	e	u			・	オ	ナ	ユ		U
xxxx0110			&	6	F	V	f	v			ヲ	カ	ニ	ヨ		
xxxx0111			'	7	G	W	g	w			ア	キ	ヌ	ラ	♀	
xxxx1000	BS		(8	H	X	h	x			イ	ク	ネ	リ		⊗
xxxx1001)	9	I	Y	i	y			ウ	ケ	ノ	ル		
xxxx1010	LF		*	:	J	Z	j	z			エ	コ	ハ	レ	!	千
xxxx1011		ESC	+	;	K	[k	{			オ	サ	ヒ	ロ	×	万
xxxx1100			,	<	L	¥	l				ヤ	シ	フ	ワ	¢	円
xxxx1101	CR		-	=	M]	m	}			ユ	ス	ヘ	ン	キ	÷
xxxx1110			.	>	N	^	n				ヨ	セ	ホ	´	n	
xxxx1111			/	?	O	_	o				ッ	ソ	マ	°	o	

【RT1 Type】

Various combinations of input power voltage, cable length, case color, and emergency stop signal, etc are possible for **RT1**.

When ordering, please order accordingly to the following specification.

* Products for OEM are handled individually, and are classified by model number.

【How To Look At Type】

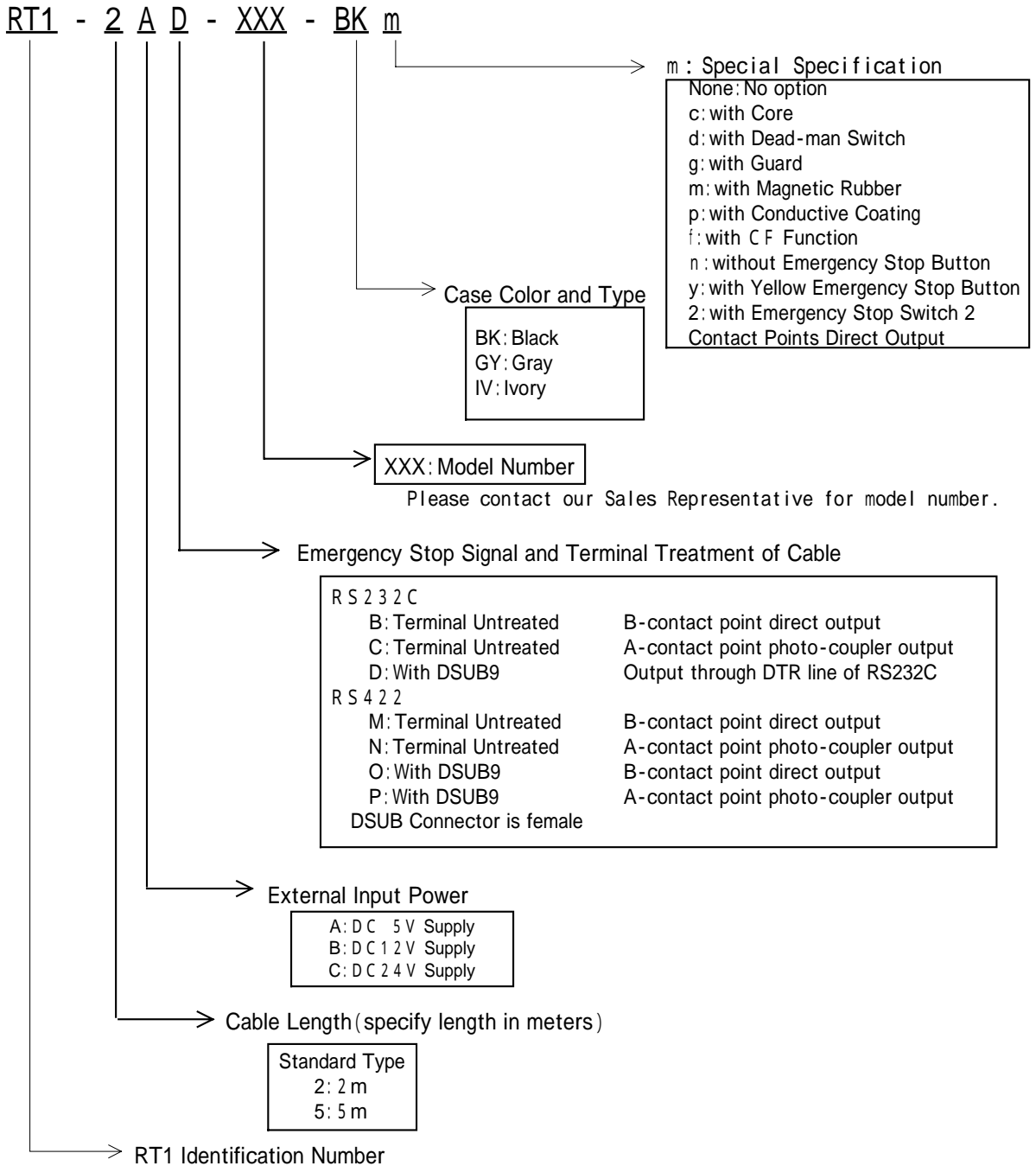

'R' is added at the end of the serial number for RoHS compliant model.

《Example of Type Specification》

RT1-2AD-002-BK : Multi-axis sheet, 2m cable, DC5V power, Emergency stop DTR line used, RS232C, Black case.

RT1-5AD-001-BK : 1-axis sheet, 5m cable, DC5V power, Emergency stop DTR line used, RS232C, Black case.

RT1-2BB-868-GYm : Multi-axis sheet, 2m cable, DC12V power, Emergency stop B-contact output, RS232C, Gray case, with Magnetic rubber.

RT1-10CM-011-BK : Multi-axis sheet, 10m cable, DC24V power, Emergency stop B-contact output, RS422, Black case.